

KM175, KM176, KM177, F4A21, 22 & 23 4SPEED FWD (With & Without Lock Up)



AUTOMATIC CHOICE



THE AUTOMATIC TRANSMISSION PARTS WAREHOUSE

A

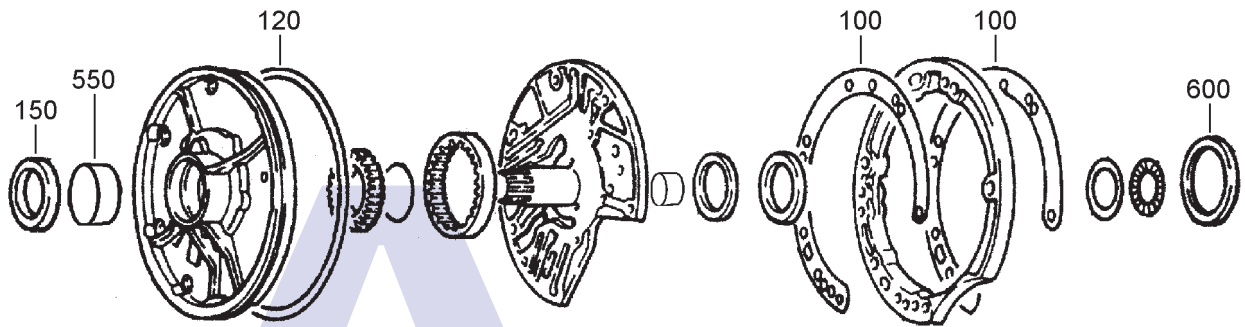

PUMP

B

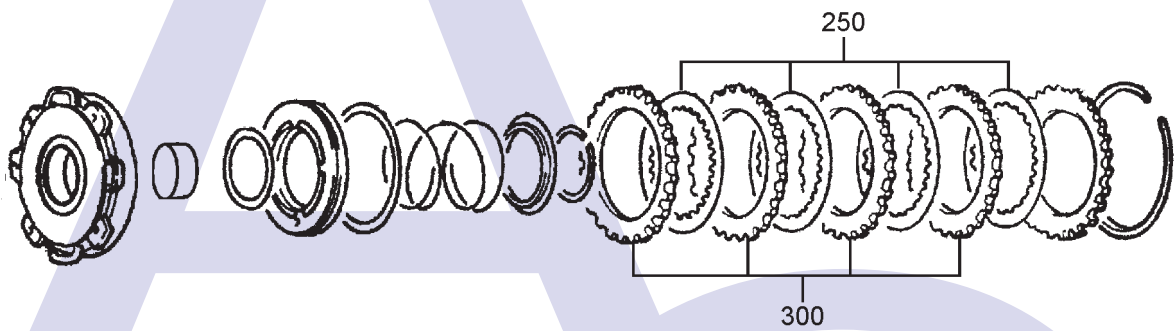

DIRECT CLUTCH

C

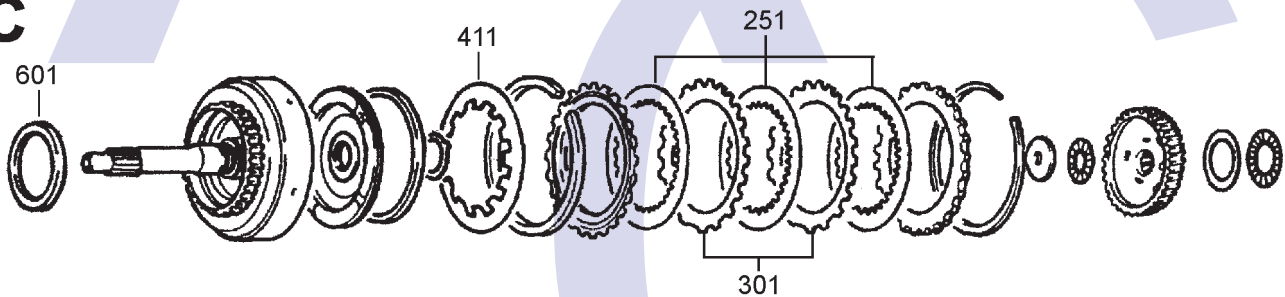

FORWARD CLUTCH

D

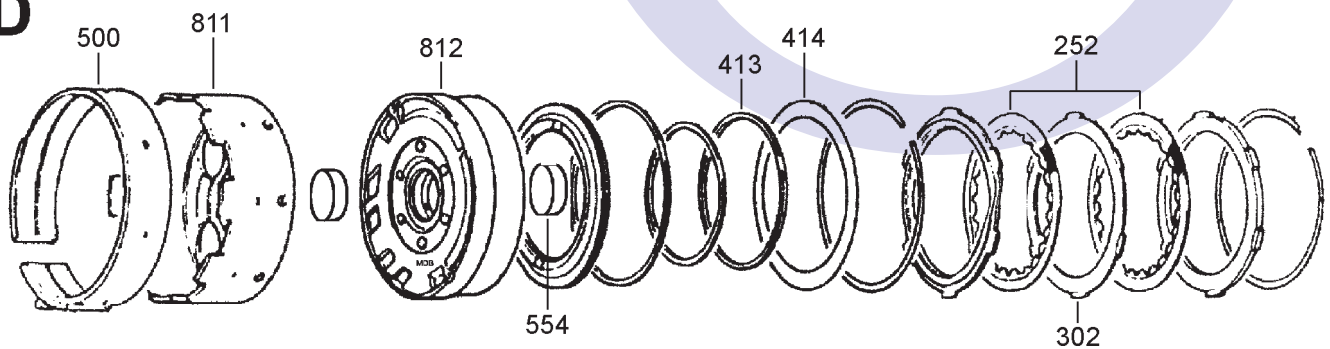

BAND AND LOW REVERSE BRAKE

KM175, KM176, KM177, F4A21, 22 & 23 4SPEED FWD (With & Without Lock Up)



AUTOMATIC CHOICE



THE AUTOMATIC TRANSMISSION PARTS WAREHOUSE

E

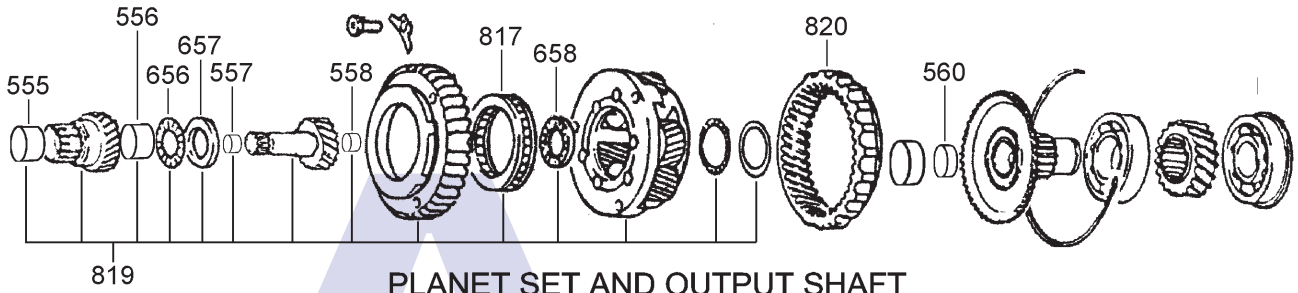

PLANET SET AND OUTPUT SHAFT

F

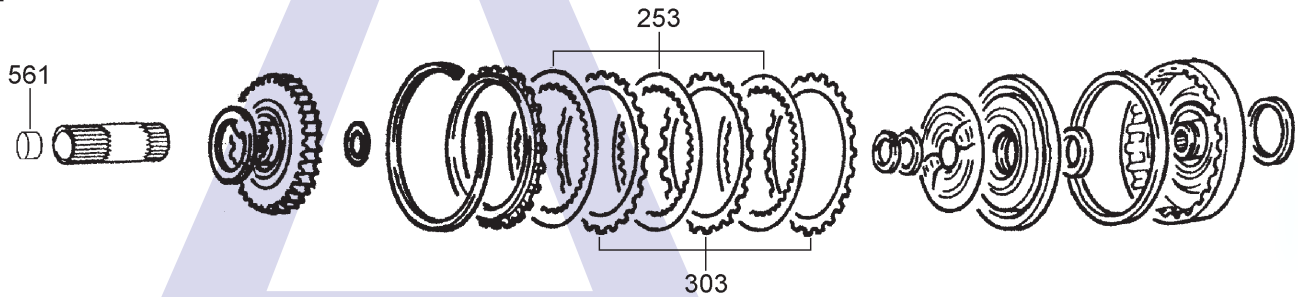

END CLUTCH (OVERDRIVE)

G

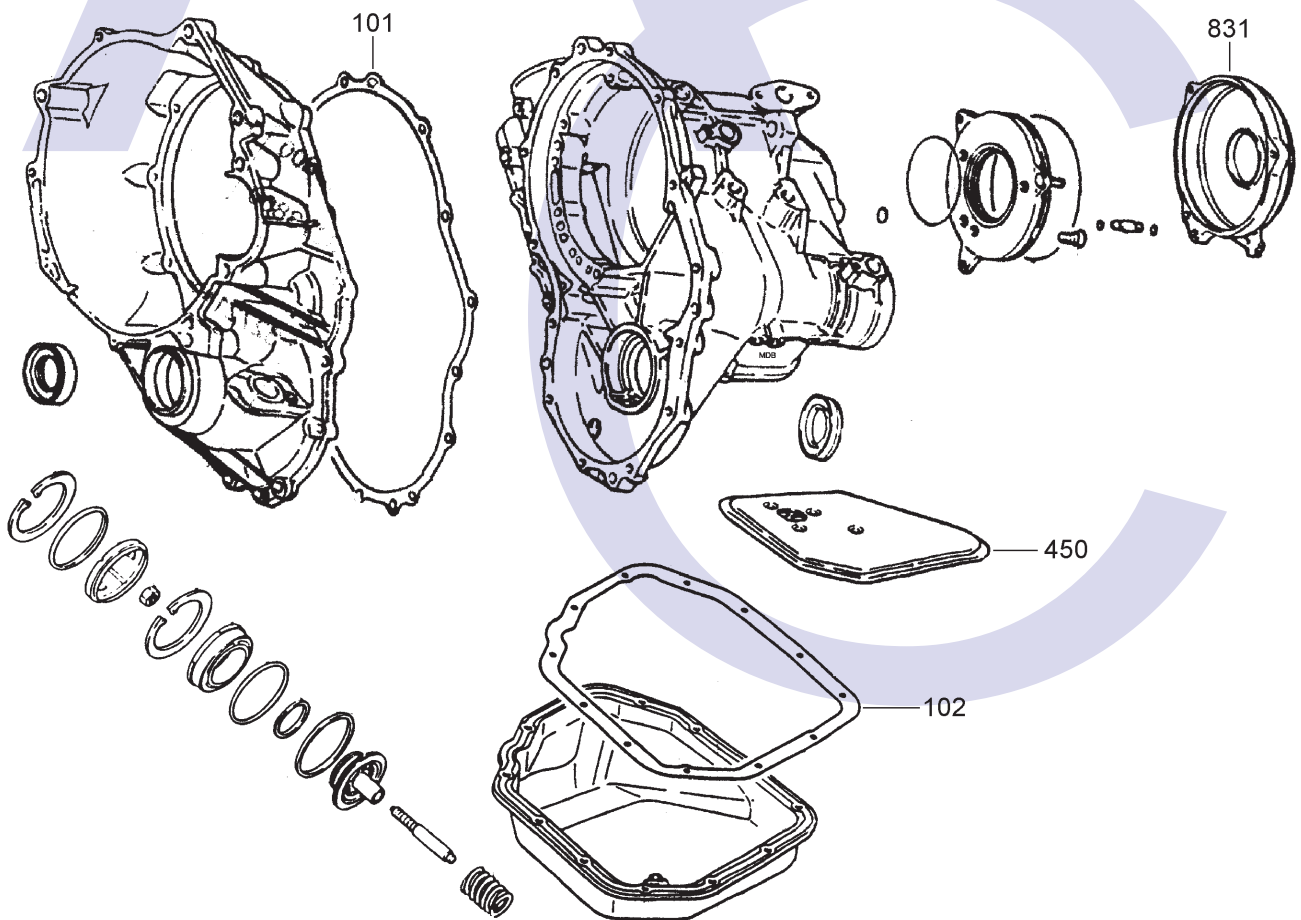

CASE AND SERVO

KM175, KM176, KM177, F4A21, 22 & 23 4SPEED FWD (With & Without Lock Up)



AUTOMATIC CHOICE



THE AUTOMATIC TRANSMISSION PARTS WAREHOUSE

ILL NO.	DESCRIPTION	YEARS	QTY	PART NO
KITS				
Kit	Overhaul Kit KM175, 177 (Transtec) (With Paper Case Gasket).....	85-88	1	KM175.OHK01
Kit	Overhaul Kit F4A21,22 & 23 Transtec (With Metal Case Gasket).....	89-ON	1	KM177.OHK01
Kit	Overhaul Kit (Precision) (KM175, 175-1, 175-2,5,7 176-7) 12 Bolt Pan	85-88	1	KM175.OHK51
Kit	Overhaul Kit (Precision) (KM177-0, 177-8) 13 Bolt Pan	85-88	1	KM175.OHK51
Kit	Overhaul Kit (Precision) (KM175-5, 6, 7, KM176-5, 7, 8, KM177-7, 8 F4A21-1, 2, F4A22-2, F4A23-2, F4A23-1)	89-98	1	KM175.OHK52
Kit	Overdrive Repair.....	85-ON	1	KM175.ORK01
Kit	Gasket & Seal (Metal Case Gasket).....	89-ON	1	KM177.GSK01
Kit	Shim Kit (End Play).....	85-ON	1	KM175.TWK02
GASKETS				
100A	Pump Gasket	85-ON	2	KM170.GAS06
101G	Case to Converter Housing Gasket (Paper).....	84-88	1	KM170.GAS04
101G	Case to Converter Housing (Metal).....	89-ON	1	KM170.GAS05
102G	Pan Gasket (12 Bolt Holes)	85-ON	1	KM170.GAS01
102G	Pan Gasket (12 Bolt Holes) (Farpack).....	85-ON	1	KM170.GAS10
102G	Pan Gasket (13 Bolt Holes)	Some	1	KM177.GAS01
102G	Pan Gasket (13 Bolt Holes) (Farpack).....	Some	1	KM177.GAS10
RUBBER COMPONENTS				
Kit	Overdrive Repair Kit Contains all Rubber Components & Overdrive Bolts Required for Overdrive Repair.....	85-ON	1	KM175.ORK01
Kit	Servo Repair (78mm).....	85-ON	1	KM175.SERK01
Kit	Servo Repair (83mm).....	85-ON	1	KM175.SERK02
Kit	Servo Repair (100mm).....	85-ON	1	KM175.SERK03
120A	Pump Body O Ring	79-ON	1	KM170.OR01
METAL CLAD SEALS				
150A	Front Pump Seal.....	79-ON	1	KM170.MCS01
NI	End Clutch Seal (16.50mm I.D.)	79-ON	1	KM175.MCS02
NI	End Clutch Seal (12.70mm I.D.)	79-ON	1	KM175.MCS03
SHAFT SEALING RINGS				
Kit	Sealing Ring Kit	85-ON	1	KM177.SRK01

ILL NO.	DESCRIPTION	YEARS	QTY	PART NO
FRICTION PLATES				
Kit	Friction Plate (Alto) (KM177)	87-88	1	KM177.FRK51
Kit	Friction Plate (Alto) (KM175, KM177).....	85-88	1	KM175.FRK51
Kit	Friction Plate (Alto) (KM175, 176, 177, F4A21/2/3)..	89-ON	1	KM175.FRK52
250B	High/Rev (Front) Friction (127 O.D. x 100 I.D. x 38T x 2.10mm Thick) Fitted Later to Some Hyundai ...	79-88	2	KM170.FRP01
250B	High/Rev (Front) Friction (127 O.D. x 104 I.D. x 38T x 1.90mm Thick)	89-ON	3	KM170.FRP04
251C	Forward (Rear) Friction (127 x 10T x 2.00mm Thick)	79-88	2	KM170.FRP02
251C	Forward (Rear) Friction (127 x 38T x 1.90mm Thick)	89-ON	3	KM170.FRP04
251C	Forward (Rear) Friction (127 x 38T x 1.70mm Thick)	00-ON	3	KM170.FRP12
252D	Low & Reverse Friction (152 O.D. x 48T x 1.80mm)	79-88	4	KM170.FRP03
252D	Low & Reverse Friction (152 O.D. x 51T x 1.85mm)	89-ON	6	KM170.FRP05
253F	Overdrive (End Clutch) (123mm OD x 1.80mm x 40T) ..	84-ON	3	KM170.FRP06
253F	Overdrive (End Clutch) (123mm OD x 1.65mm x 36T) ..	00-ON	3-4	KM170.FRP13
NOTE: Some Hyundai Transmission use early frictions in some applications as late as 1992. To avoid problems check sizes before ordering.				
STEEL PLATES				
Kit	Steel Plate (Alto) (KM177)	87-88	1	KM177.STK51
Kit	Steel Plate (Alto) (KM175, KM177).....	85-88	1	KM175.STK51
Kit	Steel Plate (Alto) (KM175, 176, 177, F4A21/2/3)..	89-ON	1	KM175.STK52
300B	High/Rev (Front) Steel (99mm I.D. x 3.80mm x 24T)	79-88	3	KM170.STP01
300B	High/Rev (Front) Steel (104.4 I.D. x 3.70mm x24T)	89-ON	3	KM170.STP02
300B	High/Rev (Front) Steel (104.4 I.D. x 3.00mm x24T)	92-ON	3	KM170.STP06
301C	Forward (Rear) Steel 99mm I.D. x 1.80mm x 24T)	79-88	2	KM170.STP03
301C	Forward (Rear) Steel (104.4 I.D. x 1.80mm x 24T)	89-ON	2	KM170.STP04
302D	Low & Reverse Brake (KM175) (127mm ID x 1.00mm x 24T)	84-88	5	KM170.STP12
302D	Low & Reverse Brake (KM177) (134mm ID x 1.00mm x 24T)	87-88	5	KM170.STP14
302D	Low & Reverse Brake (134mm ID x 1.00mm x 20T)	89-ON	5	KM170.STP15
302D	Low & Reverse Brake (134mm ID x 1.08mm x 20T)	89-ON	5	KM170.STP16
303F	Overdrive (End Clutch) (106mm ID x 0.80mm x 25T)	84-ON	3-4	KM170.STP05
303F	Overdrive (Elantra) (96mm ID x 2.50mm x 25T)	99-ON	4	KM170.STP19
303F	Overdrive (End Clutch) (96mm ID x 4.00mm x 25T)	00-ON	3-4	KM170.STP20
NOTE: Some Hyundai Transmission use early Steel Plates in some applications as late as 1992. To avoid problems check sizes before ordering.				

KM175, KM176, KM177, F4A21, 22 & 23 4SPEED FWD (With & Without Lock Up)



AUTOMATIC CHOICE



THE AUTOMATIC TRANSMISSION PARTS WAREHOUSE

ILL NO.	DESCRIPTION	YEARS	QTY	PART NO
PRESSURE PLATES				
SPRINGS & CIRCLIPS				
411C	Forward Clutch Diaphragm Spring (12 Fingers)		1	KM170.DIA03
411C	Forward Clutch Diaphragm Spring (15 Fingers)		1	KM170.DIA04
411C	Forward Clutch Diaphragm Spring (25 Fingers)		1	KM170.DIA02
413D	Low & Reverse Wave Ring (132mm O.D.)	82-88	1	KM170.DIA01
413D	Low & Reverse Wave Ring (140mm O.D.)	89-ON	1	KM170.DIA02
414D	Low & Rev Return Spring	89-ON	1	KM170.DIA05
FILTERS				
450G	Filter 9mm Thick (Dacron)	82-88	1	KM170.FIL02
450G	Filter 18mm Thick (Dacron)	83-94	1	KM170.FIL03
450G	Filter (Plastic & Metal)	92-ON	Alt	KM170.FIL04
See separate data sheet for filter identification				
BANDS				
500D	Band (40mm Wide)	79-ON	1	KM170.BAN01
500D	Kickdown Band (40mm Wide) (Borg Warner)	79-ON	1	KM170.BAN21
500D	Band (44mm Wide)	88-ON	1	KM177.BAN01
BUSHINGS				
Kit	Bush Kit	85-88	1	KM170.BK02
Kit	Bush Kit	88-ON	1	KM175.BK01
550A	Pump Bush	79-ON	1	KM170.BUS01
554D	Centre Support (Narrow) (42.926mm ID)	91-ON	1	KM175.BUS05
555E	Reverse Sun Gear (Front) (28.00mm ID)	89-ON	1	KM175.BUS04
556E	Reverse Sun Gear (Rear) (28.00mm ID)	89-ON	1	KM175.BUS04
557E	Forward Sun gear Front (20.57mm ID)	89-ON	1	KM175.BUS03
558E	Forward Sun gear Rear (20.57mm ID)	89-ON	1	KM175.BUS03
561F	Overdrive Shaft (20.57mm ID)	79-ON	1	KM175.BUS03
562E	Output Shaft (32.50mm ID)	89-ON	1	KM175.BUS02
THRUST WASHERS & BEARINGS				
Kit	Shim Kit (End Play)	85-ON	1	KM175.TWK02
600A	Thrust Washer Pump to Dir Clutch Drum Selective (3.00mm)		AR	KM170.THW04
600A	Thrust Washer Pump to Dir Clutch Drum Selective (2.60mm)		AR	KM170.THW01
600A	Thrust Washer Pump to Dir Clutch Drum Selective (2.20mm)		AR	KM170.THW02
600A	Thrust Washer Pump to Dir Clutch Drum Selective (1.80mm)		AR	KM170.THW03
601C	Thrust Washer Dir Clutch Drum to Fwd Clutch Drum Selective (2.60mm)		AR	KM170.THW01
601C	Thrust Washer Dir Clutch Drum to Fwd Clutch Drum Selective (2.20mm)		AR	KM170.THW02

ILL NO.	DESCRIPTION	YEARS	QTY	PART NO
THRUST WASHERS & BEARINGS Cont...				
601C	Thrust Washer Dir Clutch Drum to Fwd Clutch Drum Selective (1.80mm)		AR	KM170.THW03
656E	Primary to Secondary Sun gear ... Bearing (40.85mm O.D x 28.10mm I.D. x 2.00mm)	79-ON	1	KM175.TOR01
657E	Primary to Secondary Sun gear Thrust Plate (39mm O.D. x 28mm I.D. x 2.00mm)	79-ON	1	KM175.THW01
658E	Sun gear to Planet Needle Bearing (38mm O.D x 22.50mm I.D. x 3.90mm)	85-ON	1	KM175.TOR02
ELECTRONIC COMPONENTS				
Kit	Solenoid Master (KM175)	88-ON	1	KM175.SOL06
NI	A & B Shift Solenoids	88-ON	1	KM175.SOL01
NI	Pressure Solenoid	85-ON	1	KM175.SOL02
NI	Lock Up Solenoid (Hyundai)	85-ON	1	KM175.SOL02
NI	Lock Up Solenoid (Mitsubishi) ..	-92	1	KM175.SOL02
NI	Lock Up Solenoid (Mitsubishi) ..	93-ON	1	KM175.SOL03
VALVE BODY PARTS				
Kit	Valve Body Calibration Kit	All	1	KM175.SK01
NI	Manual Valve	85-ON	1	KM170.VA01
HARD PARTS				
811D	Sun Shell/Kickdown Drum (100mm Deep) 175-5, F4A22 ...	89-ON	1	KM177.POT01
812D	Centre Support (37mm Overall Hight) Uses 20 Tooth Steel Plate	89-ON	1	KM177.SUP01
812D	Centre Support (40mm Overall Hight) Uses 20 Tooth Steel Plate	89-ON	1	KM177.SUP02
817E	One Way Clutch (17.80mm Wide) Measured W.Both End Caps	84-ON	1	TH180.OWC01
819E	Planetary Repair Set (175-5, F4A22 Wide Ratio) (See Additional Data Sheet) ...	89-ON	1	KM175.PL01
819E	Planetary Repair Set (175-5, F4A21 Close Ratio) (See Additional Data Sheet) ...	89-ON	1	KM175.PL04
820E	Planetary Annulus (Use With KM175.PL01)	85-ON	1	KM175.GE01
831G	Cover - Overdrive Clutch	89-ON	1	KM177.COV01
SPECIAL ITEMS				
MANUALS & SPECIAL TOOLS				
NI	ATSG KM175 Rebuild Manual ..			KM175.MAN01
NI	ATSG KM177 Rebuild Manual ..			KM177.MAN01
Click here to view special tools for this transmission				