

RENAULT DPO, PEUGEOT CITROEN AL4 4 SPEED FWD (Electronic Control)



AUTOMATIC CHOICE



THE AUTOMATIC TRANSMISSION PARTS WAREHOUSE

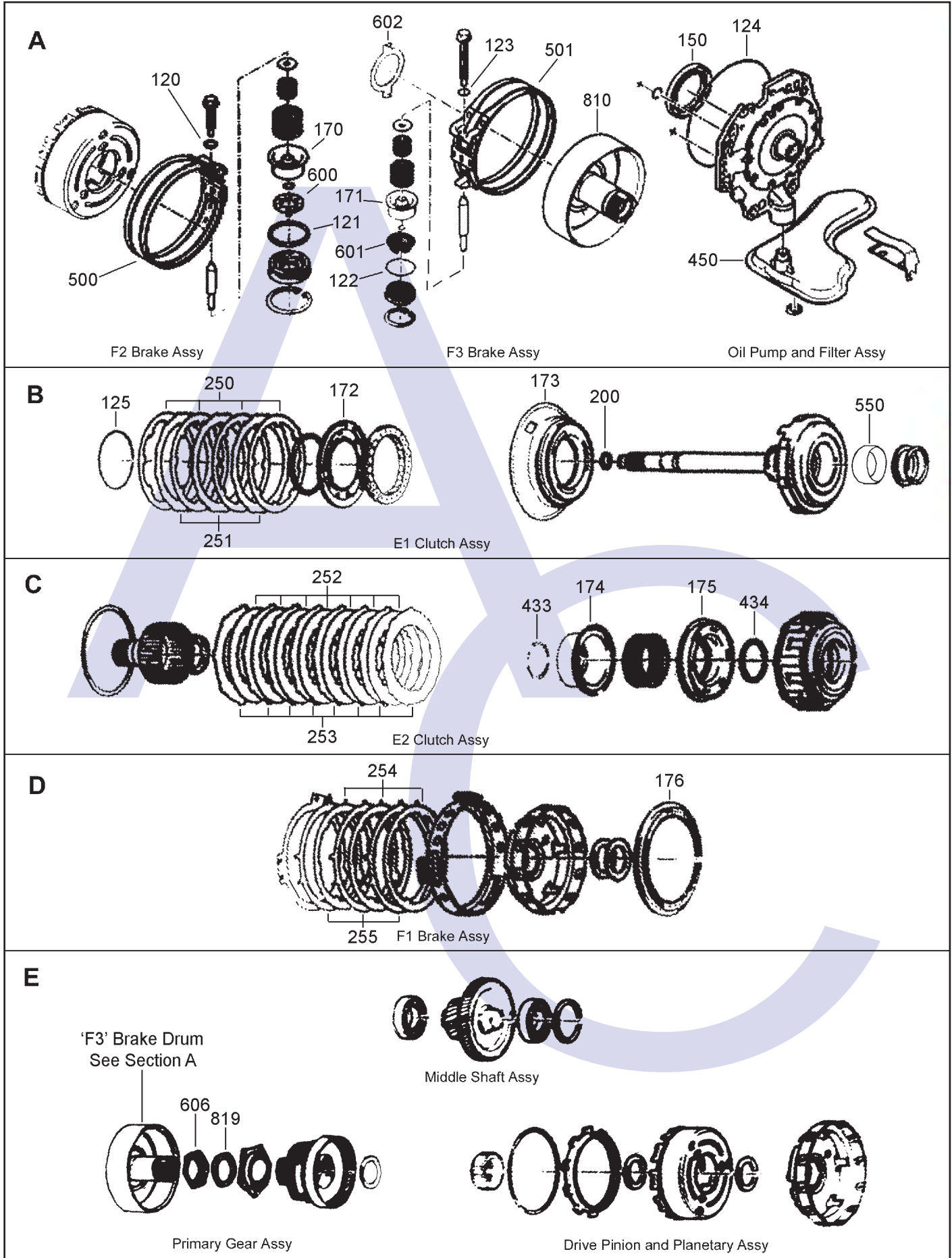

RENAULT DPO, PEUGEOT CITROEN AL4 4 SPEED FWD (Electronic Control)



AUTOMATIC CHOICE



THE AUTOMATIC TRANSMISSION PARTS WAREHOUSE

F

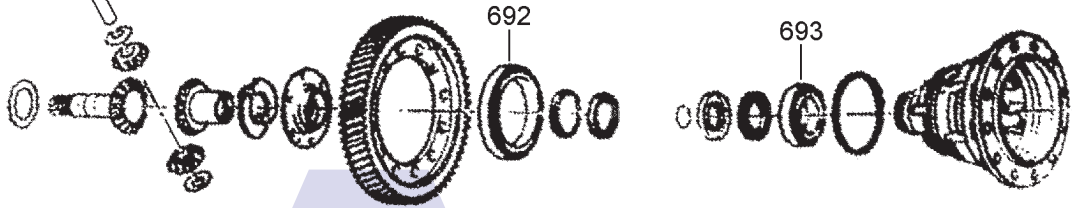

Differential Assy

G

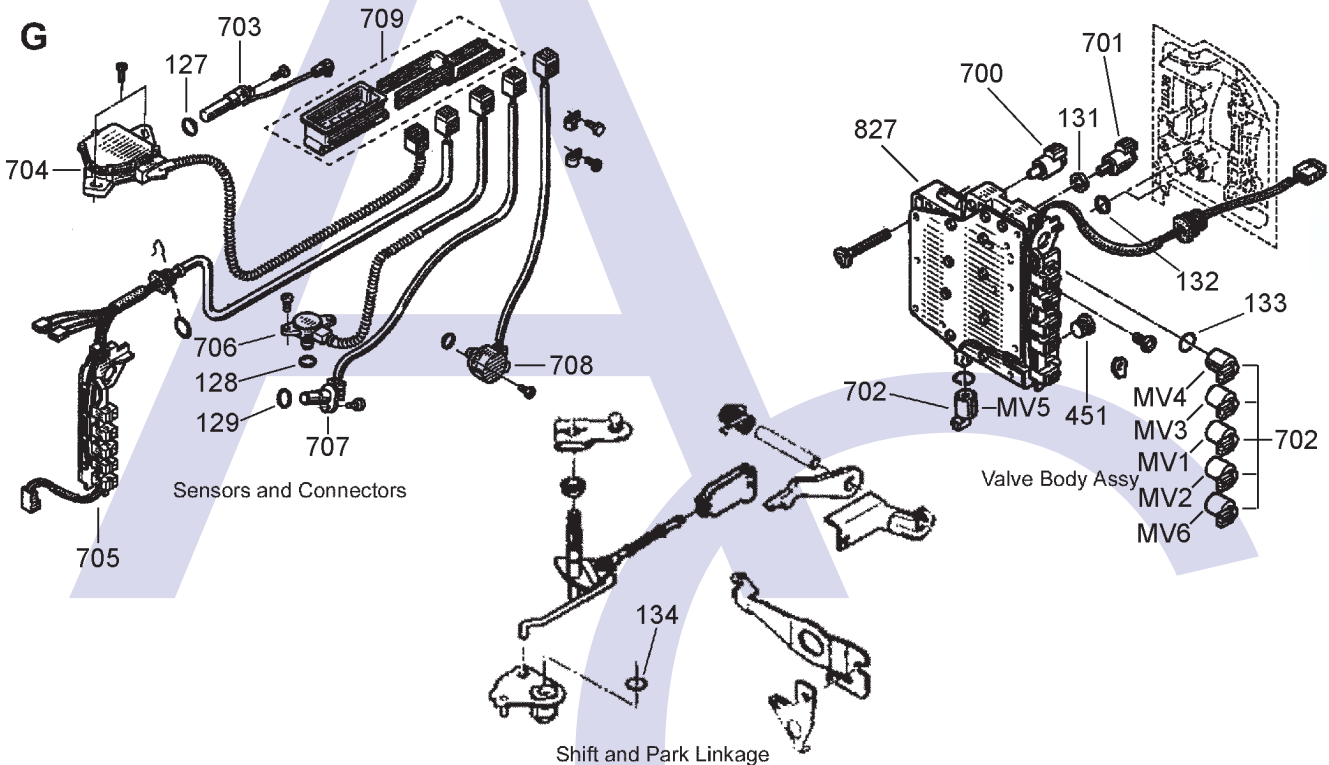

Sensors and Connectors

Valve Body Assy

Shift and Park Linkage

H

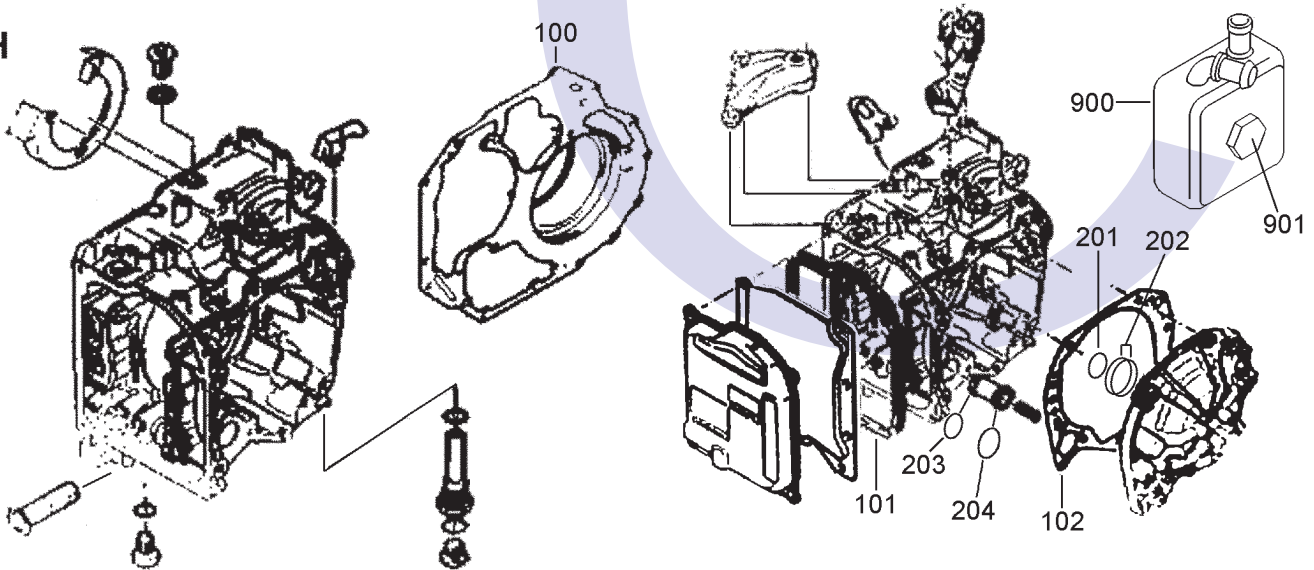

Transmission Casing

RENAULT DPO, PEUGEOT CITROEN AL4 4 SPEED FWD (Electronic Control)



AUTOMATIC CHOICE



THE AUTOMATIC TRANSMISSION PARTS WAREHOUSE

ILL NO.	DESCRIPTION	YEARS	QTY	PART NO
KITS				
Kit	Gasket and Seal	All	1	DPO.GSK01
Kit	Overhaul Kit (EOM) Without Metal Gaskets.....	All	1	DPO.OHK01
Kit	Overhaul Kit (Transtec) Without Metal Gaskets.....	All	1	DPO.OHK04
Kit	Overhaul Kit (Aftermarket) With OEM Parts	All	1	DPO.OHK05
Kit	Overhaul Kit (Precision) Without Metal Gaskets.....	All	1	DPO.OHK51
Kit	Piston Kit.....	All	1	DPO.PISKIT
Kit	Copper Washer Kit.....	All	1	DPO.WK01
Kit	'O' Ring Kit.....	All	1	DPO.ORK01
GASKETS				
100H	Metal Case Gasket (Renault) (Use With DPO.GAS06).....	All	1	DPO.GAS03
100H	Metal Case Gasket (Citroen) (Use With DPO.GAS06).....	All	1	DPO.GAS05
100H	Late Case Gasket Bowl (Citroen) (Use With DPO.GAS03 & 05) ...	All	1	DPO.GAS06
101H	Valve Body Cover	All	1	DPO.GAS01
102H	Rear Cover (Steel & Rubber)....	All	1	DPO.GAS02
RUBBER COMPONENTS				
120A	Band Bolt 'O' Ring.....	All	2	DPO.OR04
121A	'F2' Servo 'O' Ring	All	1	DPO.OR09
122A	'F3' Servo 'O' Ring	All	1	DPO.OR10
124A	Pump 'O' Ring.....	All	1	DPO.OR01
NI	Pump Bolt 'O' Ring.....	All	10	DPO.OR02
125B	'E1' 'O' Ring	All	1	DPO.OR03
127G	Sensor 'O' Ring (Output Speed Sensor).....	All	1	DPO.OR06
128G	Sensor 'O' Ring (Oil Pressure Sensor)	All	1	DPO.OR07
129G	Sensor 'O' Ring (Input Speed Sensor).....	All	1	DPO.OR08
131G	EPC Solenoid Seal	All	2	DPO.SQR04
132G	Valve Body to Case Seal	All	2	DPO.SQR03
133G	Shift Solenoid 'O' Ring	All	6	DPO.OR11
134G	Detent Selector 'O' Ring	All	1	DPO.OR05
NI	Speedo 'O' Ring.....	All	1	DPO.OR12
NI	Solenoid Loom 'O' Ring	All	1	DPO.OR13
NI	Heat Exchanger Seal (Outer)....	All	1	DPO.SQR01
NI	Heat Exchanger Seal (Inner)	All	1	DPO.SQR02
METAL CLAD SEALS				
150A	Converter Seal.....	All	1	DPO.MCS01
NI	Driveshaft (Left Hand).....	All	1	DPO.MCS02
NI	Driveshaft (Right Hand)	All	1	DPO.MCS03
NI	Selector Shaft	All	1	DPO.MCS04
MOULDED PISTONS				
Kit	Piston Kit (Less Servo Pistons) All	All	1	DPO.PISKIT
Kit	Piston Kit (With Servo Pistons) . All	All	1	DPO.PISKIT01
170A	'F2' Servo Piston (65.00 x 24.40mm).....	All	1	DPO.SER02
171A	'F3' Servo Piston (46.00 x 23.50 x 8.00mm)	All	1	DPO.SER03
172B	'E1' Accumulator Piston	All	1	DPO.PIS04
173B	'E1' Moulded Piston	All	1	DPO.PIS02
174C	'E2' Accumulator Piston	All	1	DPO.PIS03
175C	'E2' Moulded Piston	All	1	DPO.PIS05
176D	'F1' Moulded Piston	All	1	DPO.PIS01

ILL NO.	DESCRIPTION	YEARS	QTY	PART NO
SEALING RINGS				
Kit	Shaft Sealing Ring Kit.....	All	1	DPO.SRK01
Kit	Shaft Sealing Ring Kit (OEM) ...	All	1	DPO.SRK02
200B	Input Shaft (18.00 x 1.80 x 1.75mm).....	All	1	DPO.SSR01
201H	Rear Cover (Inner) (32.50 x 28.50 x 2.00mm).....	All	1	DPO.SSR03
202H	Rear Cover (Outer) (Transtec) (54.00 x 50.00 x 2.00mm).....	All	2	DPO.SSR02
203H	Accumulator (Inner) (32.50 x 28.50 x 2.00mm).....	All	1	DPO.SSR03
204H	Accumulator (Outer) (25.00 x 21.00 x 2.00mm).....	All	1	DPO.SSR04
FRICITION PLATES				
Kit	Friction Kit.....	All	1	DPO.FRK01
Kit	Friction Kit (Alto)	All	1	DPO.FRK51
250B	'E1' 160 x 120 x 1.60mm (8 Internal Teeth).....	All	3	DPO.FRP01
250B	'E1' 160 x 120 x 1.60mm (8 Internal Teeth) (Allomatic).....	All	3	DPO.FRP11
251B	'E1' 165 x 133 x 1.60mm (12 External Teeth).....	All	3	DPO.FRP02
251B	'E1' 165 x 133 x 1.60mm (12 External Teeth) (Allomatic) ..	All	3	DPO.FRP12
251B	'E1' 165 x 133 x 1.60mm (Early 12 External 15.7mm Teeth)	All	3	NLA
252C	'E2' 118 x 78 x 1.60mm (20 Internal Teeth).....	All	7	DPO.FRP03
252C	'E2' 118 x 78 x 1.60mm (20 Internal Teeth) (Allomatic)....	All	7	DPO.FRP13
253C	'E2' 124 x 82 x 1.60mm (8 External Teeth).....	All	7	DPO.FRP04
253C	'E2' 124 x 82 x 1.60mm (8 External Teeth) (Allomatic)....	All	7	DPO.FRP14
254D	'F1' 171 x 137 x 1.60mm (6 Internal Teeth).....	All	3	DPO.FRP05
254D	'F1' 171 x 137 x 1.60mm (6 Internal Teeth) (Allomatic).....	All	3	DPO.FRP15
255D	'F1' 199 x 146 x 1.60mm (6 External Teeth).....	All	3	DPO.FRP06
255D	'F1' 199 x 146 x 1.60mm (6 External Teeth) (Allomatic)....	All	3	DPO.FRP16
PRESSURE PLATES				
SPRINGS & CIRCLIPS				
433C	'E2' Upper Circlip (47.00 x 40.00 x 1.50mm).....	All	1	DPO.CIR01
434C	'E2' Drum Retainer Circlip (46.00 x 47.00 x 2.00mm).....	All	1	DPO.CIR02
FILTERS				
450A	Pan Filter (Aftermarket).....	All	1	DPO.FIL01
450A	Pan Filter (OEM).....	All	1	DPO.FIL10
451G	Valve Body Filter	All	1	DPO.FIL02

RENAULT DPO, PEUGEOT CITROEN AL4

4 SPEED FWD (Electronic Control)



AUTOMATIC CHOICE



THE AUTOMATIC TRANSMISSION PARTS WAREHOUSE

ILL NO.	DESCRIPTION	YEARS	QTY	PART NO
BANDS				
500A	'F2' Band Reverse (OEM)..... All	All	1	DPO.BAN01
500A	'F2' Band Reverse (Aftermarket)..... All	All	1	DPO.BAN02
501A	'F3' Band Forward 1st & 2nd (OEM)..... All	All	1	DPO.BAN01
501A	'F3' Band Forward 1st & 2nd (Aftermarket)..... All	All	1	DPO.BAN02
BUSHINGS				
Kit	Bushing Kit..... All	All	1	DPO.BK01
Kit	Bushing Pump Stator (Contains DPO.BUS04 & BUS05)..... All	All	1	DPO.BUS06
550B	'E1' Clutch Drum Bushing..... All	All	1	DPO.BUS02
NI	Pump Bush (Standard)..... All	All	1	DPO.BUS01
NI	Pump Bush (Oversize)..... All	All	1	DPO.BUS03
NI	Bush, Pump Stator (Small)..... All	All	1	DPO.BUS04
NI	Bush, Pump Stator (Large)..... All	All	1	DPO.BUS05
NI	Bush, Planetary (One Piece)..... All	All	1	DPO.BUS07
THRUST WASHERS & BEARINGS				
Kit	Selective Thrust Kit ('F2'/'F3' Servo)..... All	All	1	DPO.TWK02
600A	'F2' Selective Thrust Kit..... All	All	1	DPO.THW03
601A	'F3' Selective Thrust Kit..... All	All	1	DPO.THW03
602A	Plastic Thrust Washer (2 Tang 63 x 48mm)..... All	All	1	DPO.THW02
606E	Hexagonal Nut Thrust..... All	All	1	DPO.THW01
692F	Diff Bearing L/H..... All	All	1	DPO.BE02
693F	Diff Bearing R/H..... All	All	1	DPO.BE01
693F	Bearing-Diff R/H (Update) (41mm x 72mm x 15.50mm)..... All	All	1	DPO.BE03
ELECTRICAL COMPONENTS				
700G	EPC Solenoid (NLA See Note) -09/03	-09/03	1	DPO.SOL01
700G	EPC Solenoid (See Note) (OEM)..... 10/03-	10/03-	1	DPO.SOL03
701G	Lock Up Sol (NLA See Note) ... -09/03	-09/03	1	DPO.SOL01
701G	Lock Up Sol (See Note) (OEM Boxed)..... 10/03-	10/03-	1	DPO.SOL03
701G	Lock Up Sol (See Note) (OEM Loose)..... 10/03-	10/03-	1	DPO.SOL13
702G	Shift Solenoid..... All	All	6	DPO.SOL02
703G	Output Speed Sensor..... All	All	1	DPO.ELE06
704G	Range Switch (Megane, Clio & Scenic)..... All	All	1	DPO.ELE01
705G	Valve Body Loom (Megane, Clio & Scenic)..... All	All	1	DPO.ELE02
706G	Pressure Sensor (Megane, Clio & Scenic)..... All	All	1	DPO.ELE03
706G	Pressure Sensor (Citroen)..... All	All	1	DPO.ELE11
707G	Input Speed Sensor (Megane, Clio & Scenic)..... All	All	1	DPO.ELE04
708G	Heat Exchanger Temp Sensor.. All	All	1	DPO.ELE05
708G	Heat Exchanger Temp Sensor (Late 2 Pin Connector that doesn't fit into Multi Case Connector)..... All	All	1	DPO.ELE12
708G	Heat Exchanger Blanking Plug (Late models without Sensor) ... All	All	1	DPO.ELE14
709G	Modular Plug Assembly (Grey) . All	All	1	DPO.ELE13

ILL NO.	DESCRIPTION	YEARS	QTY	PART NO
ELECTRICAL COMPONENTS Cont...				
Renault DPO, Peugeot & Citroen AL4 Pressure and Lock-Up Solenoids				
<p>The DPO.SOL03 solenoid is the latest design type (Silver with black connector), this supersedes the earlier design DPO.SOL01 with white connector which is no longer available. When replacing solenoids of the previous design, both the lock-up and the pressure regulating solenoid must be replaced together and vehicle returned to the dealer to have the ECU reprogrammed. This is necessary because the pulse width modulation frequency is different on the later design. Approximate dates of changeover to the new design are as follows: Megane 2, September 2003, Laguna Jan 2004 & all other models from March 2004, Peugeot & Citroen Models from September 2003.</p>				
VALVE BODY PARTS				
Kit	Oversized Pressure Regulator Valve Repair Kit (Requires Reamer Tool DPO.VA03 and Valve Body Fixture AG4.VA05) (Sonnax@ Click here for Info) ... All	All	1	DPO.VA02
Kit	Reamers, Guides & Guide Pin Set for DPO.VA02 (Sonnax@ Click here for Info)..... All	All	1	DPO.VA03
NI	Plastic Valve Body Plug Set..... All	All	1	DPO.VA01
HARD PARTS				
810A	'F3' Brake Drum..... All	All	1	DPO.DRU03
819E	Nut (Primary Gear Assy) (125.00 x 54.00 x 7.00mm)..... All	All	1	DPO.NUT01
827G	Valve Body Assy (Exchange) With Early Solenoids (Renault) Can be fitted to Citroen/Peugeot if seperator plate is changed All	All	1	DPO.VB01
827G	Valve Body Assy (Exchange) With Late Solenoids (Renault) Can be fitted to Citroen/Peugeot if seperator plate is changed All	All	1	DPO.VB02
SPECIAL ITEMS				
NI	Washer Cooler Bolt (Copper/Rubber)..... All	All	1	DPO.WA01
900H	Heat Exchanger (Megane).....	All	1	DPO.COOL01
900H	Heat Exchanger (9 Row) (Has two straight pipes).....	All	1	DPO.COOL08
900H	Heat Exchanger (12 Row, 42mm) (Requires Longer Bolt DPO.COOL03) (Has one bent pipe, one straight pipe)	All	1	DPO.COOL02
900H	Heat Exchanger (12 Row, 42mm) (Requires Longer Bolt DPO.COOL03) (Has two straight pipes).....	All	1	DPO.COOL04
901H	Cooler Bolt, (12 Row Cooler).... All	All	1	DPO.COOL03
901H	Cooler Bolt, (6 Row Cooler) (Use with DPO.COOL06)..... All	All	1	DPO.COOL07
NI	Air to Oil Cooler Adaptor (Click here for More Info)..... All	All	1	DPO.COOL06
NI	'F3' (Front) Band Anti Rattle Spring (Click Here For Information)..... All	All	1	DPO.SPR01
TOOLS & MANUALS				
NI	Universal Valve Body Fixture for use with Sonnax@ Valve Body Repair kits (Click here for Information)..... All	All		AG4.VA05
Click here to view special tools for this transmission				