

FORD-O-MATIC 2 SPEED 1959-64

2 Speed RWD (Hydraulic Control)



AUTOMATIC CHOICE



THE AUTOMATIC TRANSMISSION PARTS WAREHOUSE

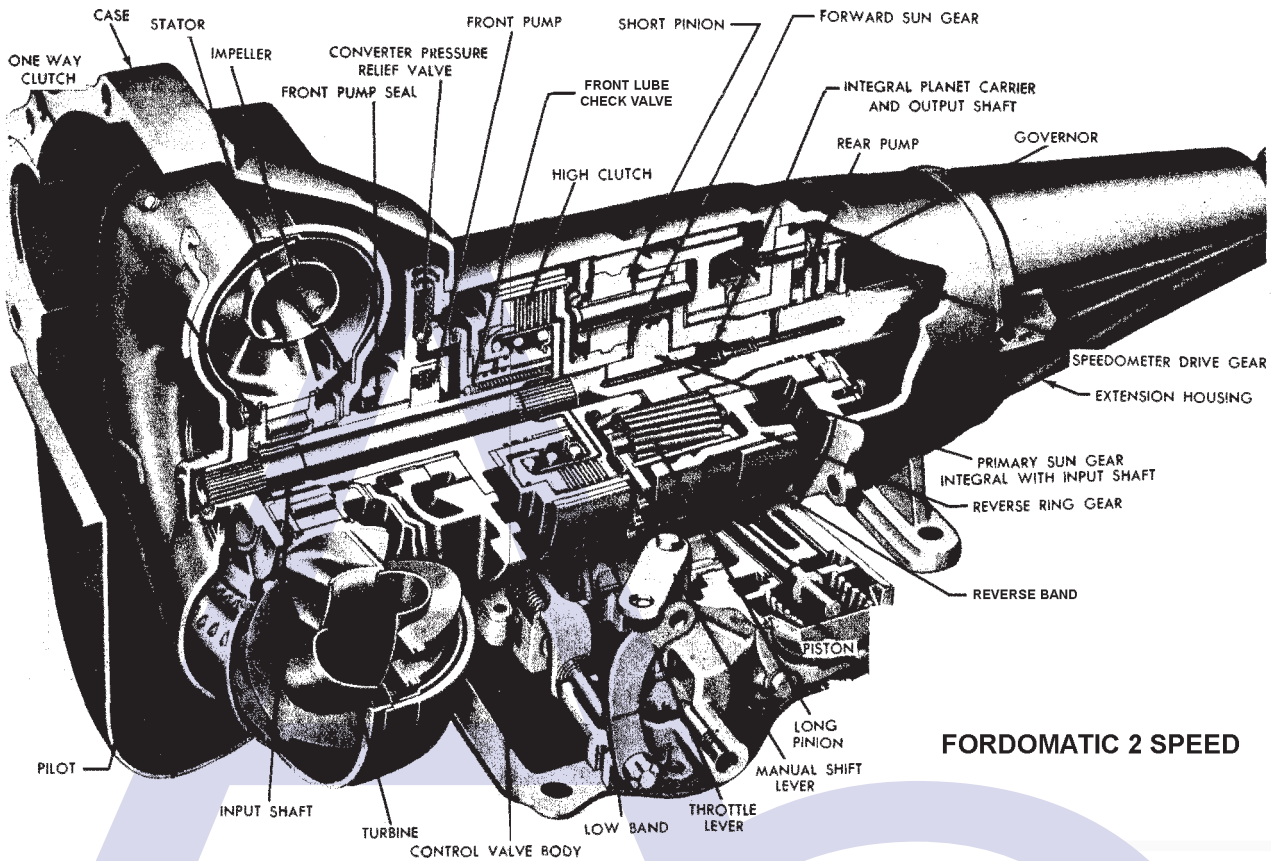

FORDOMATIC 2 SPEED

- APPLICATION 2 SPEED COMET DRIVE COMET, 1961**
FORD-O-MATIC FAIRLANE, 1962-64
FALCON & MUSTANG, 1961-64
FORD, 1959-63
MERC-O-MATIC COMET, 1962-64
METEOR, 1962-63
MERCURY, 1961-63
EDSEL, 1959-60

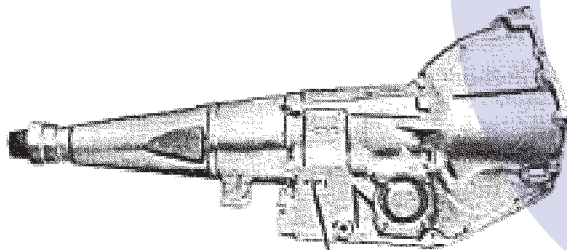

Model stamped into right hand side of case

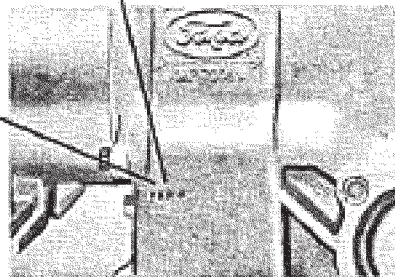

Transmission housing is aluminium with bell housing and main case as 1 piece, the pan has 14 bolts . There are two external servo covers, the front has 6 bolts the rear 4. There is no modulator and the bottom of the bell housing is chopped off at the bottom similar to a GM style transmission for TC bolt access. Fomoco is cast into the transmission on the right hand side and the model number is stamped below, see fig. 1.

FORD-O-MATIC 2 SPEED 1959-64

2 Speed RWD (Hydraulic Control)



AUTOMATIC CHOICE



THE AUTOMATIC TRANSMISSION PARTS WAREHOUSE

ILL NO.	DESCRIPTION	YEARS	QTY	PART NO
KITS				
Kit	Master Overhaul Kit	1959-64	1	FORD2S.MOHK01
Kit	Overhaul Kit	1959-64	1	FORD2S.OHK01
GASKETS				
RUBBER COMPONENTS				
METAL CLAD SEALS				
MOULDED PISTONS				
SEALING RINGS				
FRICTION PLATES				
STEEL PLATES				
PRESSURE PLATES				
SPRINGS & CIRCLIPS				
FILTERS				
NI	Pick Up Filter.....	1959-64	1	FORD2S.FIL01
BANDS				
NI	Front Band	1959-64	1	FORD2S.BAN01
BUSHINGS				

ILL NO.	DESCRIPTION	YEARS	QTY	PART NO
THRUST WASHERS & BEARINGS				
ELECTRICAL COMPONENTS				
VALVE BODY PARTS				
HARD PARTS				
SPECIAL ITEMS				
TOOLS & MANUALS				